

DEPARTMENT OF THE ARMY  
U.S. Army Corps of Engineers  
Washington, DC 20314-1000

CEMP-ET

ETL 1110-3-483

Technical Letter  
No. 1110-3-483

23 March 1998

Engineering and Design  
CLOTHES DRYER EXHAUST VENTING

## **Distribution Restriction Statement**

Approved for public release; distribution is unlimited.

Technical Letter  
No. 1110-3-483

23 March 1998

Engineering and Design  
CLOTHES DRYER EXHAUST VENTING

1. Purpose. This letter provides basic design guidance for exhaust venting systems for residential-type electric and gas clothes dryers.
2. Applicability. This letter applies to all HQUSACE elements and USACE commands having military construction and design responsibility.
3. Reference. National Fire Protection Association (NFPA) 54, *National Fuel Gas Code*.
4. Distribution. Approved for public release; distribution is unlimited.
5. Background. Exhaust venting of clothes dryers must be adequate to prevent accumulation of lint in the dryer and exhaust system and to remove humidity from the space. Improper venting can allow lint to build up and create a fire hazard. There are numerous laundry room layouts that affect the design of clothes dryer exhaust ventilation. Layout variations include individual dryers, individual dryer banks, stacked dryer banks, and multi-story laundry rooms. The ideal arrangement is to provide an individual exhaust for each dryer and vent directly to the outside. This requires that dryers be located directly adjacent to an exterior wall. However, this is not always possible, especially when renovating an existing facility or when dealing with unique facility requirements. Difficulties arise when the dryers are not located adjacent to an exterior wall. This technical letter provides basic guidelines for developing reasonable design approaches for clothes dryer exhaust venting systems.
6. General Guidance. The basic design and arrangement of exhaust venting systems for clothes dryers will be based on the following principles:
  - a. Gas-fired clothes dryer will conform to requirements of NFPA 54.
  - b. The ideal arrangement for dryer exhaust venting system is to provide an individual exhaust vent for each dryer, duct to the outside (See Detail No. 2). A variation of this arrangement is depicted in Detail No. 1. Normally these arrangements require that the laundry room be located adjacent to the outside and the back of each dryer located on an exterior wall to allow ducting directly to the outside.
  - c. When the arrangement indicated in item b is not feasible, a manifold exhaust arrangement is another design approach (See Detail Nos. 3, 4, and 5). This arrangement involves the use of a

common exhaust manifold duct or plenum to collect multiple dryer exhausts and convey this exhaust to the outside. There are disadvantages associated with this configuration. One problem is that this system configuration requires that the manifold duct be sized to accommodate all of the dryers operating at once. This sizing requirement, in turn, causes the velocity within the manifold duct to be reduced when all dryers are not in operation. This reduction in velocity can prevent lint from remaining airborne and being exhausted outside. Instead, the lint collects within the manifold duct. An exhaust fan can be provided to supplement air flow when all dryers are not operating and provide the velocity needed to keep lint airborne (See Detail No. 5). If an exhaust fan is used, it is recommended that it be automatically operated by control circuitry when any dryer is in operation.

d. The systems should be designed to facilitate periodic inspection of the manifold and the exhaust duct and removal of accumulated lint. An adequate number of clean-outs and access panels should be provided and should be simple to operate. Tools should not be required to access or open clean-outs.

e. Where booster fans are used, the motor should be located outside of the air stream (See Detail Nos. 5 and 6).

f. Makeup air should be provided for exhaust dryers, either provided from indoors or outdoors.

## 7. Technical Guidance.

a. Typical large heavy-duty residential type dryers exhaust 180-225 cfm of air. Appropriate quantities of make-up air should be provided. Exhaust air quantities may vary depending on the actual type of dryer. Manufacturers data on the type of dryer used should be consulted when determining exhaust air cfm values. Makeup air can be provided from within the building or from outside.

b. A manifold exhaust duct system may be used when multiple dryers are used. Size manifold duct to maintain recommended velocities (approximately 1200 fpm) based on all dryers operating at once. Each section of the manifold duct will be sized to handle the total amount of dryers upstream of that particular section. Some manufacturer's design guidance indicates that where manifold duct run exceeds twenty (20) feet, increase duct size by ten (10) percent. A maximum of four (4) dryers may be connected to a central horizontal duct of proper size without requiring an auxiliary booster fan (See Detail No. 3 and 4). The manifold duct should be round in lieu of rectangular to reduce lint accumulation. Manifold ducts which handle outside make-up air will be insulated as required for cold air ducts.

c. A back draft damper will be provided in each branch duct from each dryer prior to

connecting to the manifold. This prevents air from flowing into any dryer not in operation.

d. Where a manifold duct terminates outside, use of a vent hood is not recommended. A hinged wall louver with 19 mm (3/4") bird screen is the recommended wall termination device for exhausting air to the outdoors. A long radius bend or prefabricate wall cap, sized to accommodate the venting requirements of all the dryers and to reduce excessive back pressure and equipped with bird screen, are other alternatives that may be used. Wall termination device should be removable and accessible. Periodic inspection and cleaning of the louver or vent cap is required. Only experience can dictate the frequency of cleaning required. The outlet of the manifold duct will have a minimum clearance of eighteen (18) inches from any obstructions.

e. In general, booster fans are not recommended. Where booster fans are necessary to achieve proper exhausting (see Detail Nos. 5 and 6), fans should be the open-wheel radial type (i.e., paddle wheel) suitable for conveying lint and suitable for the temperatures encountered. Fans should be equipped with grease taps on the wheel, and fan shafts should be equipped with a heat slinger to dissipate heat build-up along the shaft and reduce potential for premature bearing grease dry-out. Fans should be equipped with an access (service) door to facilitate maintenance. Fans that allow the accumulation of lint, such as squirrel-cage blower fans, must be avoided. It is important that the designer analyze space requirements when booster fans are used, especially on renovated building designs. Fans will be sized to handle the total air volume exhausted by all dryers and sized to handle the highest static pressure required by the exhaust system. A differential pressure vent (i.e., weighted gravity damper) will be provided at the beginning of the duct to vary the amount of room/outside air pulled by the fan based on the number of dryers in use at any given time. The gravity damper in the manifold duct will be set to barely open when all dryers are in operation and the exhaust fan operating. With all dryers off and the booster fan operating, the gravity dampers in each dryer exhaust duct will be set to barely close.

f. Booster fan operation will automatically operate when any dryer in the system is in operation. This can be accomplished by utilizing a current sensing relay for each dryer electrical circuit. Upon operation of any dryer, current is sensed and the exhaust fan is energized. When current is not sensed, the exhaust fan is de-energized. The current sensing relays can be located at the electrical panel that serve the dryers. A time-delay feature in the exhaust fan operation will be provided. The intent of the fan delay operation is to clear the main exhaust duct of lint prior to exhaust fan shut-off, thus preventing lint build-up within the main duct. The designer will coordinate fan control sequence and arrangement with the electrical designer.

g. Some manufacturers do not recommend supplemental lint screens/filter. They increase back pressure on the system and reduce performance. The designer will evaluate project specific parameters to arrive at the optimum design which complies with dryer manufacturers recommendation's and is as maintenance-free as possible.

h. Duct exhaust from each dryer must meet the turn (elbow) and lengths requirements established by the dryer manufacturers. Different manufacturers have different requirements. Two (2) ninety degree elbows with twenty (20 ) feet of four (4) inch diameter flexible metallic duct and a four (4) inch wall cap generally reflects the average maximum limits for large heavy-duty residential-type dryers. For each additional ninety degree elbow in excess of the two indicated, the maximum duct length (20 ft) requirements shall be reduced by eight (8) to ten (10) feet. Where dryer exhaust duct lengths exceed twenty (20) feet, rigid metallic duct should be used and the vent duct size may be increased up to six (6) inches to lower the amount of back pressure placed on the dryer unit. This increase in duct size may increase the amount of cleaning maintenance required due to reduced airflow velocity within the duct. A clean-out is recommended where vent duct lengths exceed twenty (20) feet. In no case shall the length of the exhaust vent duct exceed thirty (30) feet, without a booster fan.

i. The individual exhaust duct from each dryer will be four (4) inch diameter flexible metal duct for residential type dryers, except in individual family housing units. In individual family housing units, exhaust ducts may be four (4) inch diameter non-metallic flexible duct. Where individual exhaust duct connects to a central exhaust system, the angle at which the individual duct enters the central duct will be no greater than forty-five (45) degrees. A maximum entry angle of thirty (30) degrees is recommended by some manufacturers.

j. Provisions will be made to allow for periodic inspections and clean-out of lint accumulation in the duct system and at fan (if provided). Clean-outs will be easy to use and will not require the use of tools to operate. Additional access doors should be provided for manifolded systems, especially systems with larger duct sizes utilizing booster fans. In manifold arrangement with multiple dryers, access doors will be located a minimum of every eight (8) feet. Clean-outs and access doors will be indicated on the drawing plans.

k. For dryers located in basements, only flexible metal duct should be used. For basement window installations, prefabricated window plates (usually available from dryer manufacturers) with four (4) inch precut holes can be used. These are usually available in aluminum or plastic material. The plastic plate has the advantage of allowing light to pass through the area.

l. Where exhaust vents are ducted up through the roof (See Detail No. 7), the system will adhere to turns (elbows) and length requirements list above in Paragraph 7h. Provide vent cap at exhaust termination outside. Provide appropriate vent collar and flashing as required. Verify firestopping requirements.

m. Where dryers are located in recessed areas (See Detail No. 9), obstructions which hinder dryer operation must be avoided. The following guidance will be considered.

- (1) If a shelf or cabinet exists above dryer, the bottom of shelf must not be closer than fifteen

(15) inches from top of dryer, and the shelf must not extend more than fourteen (14) inches from the rear wall.

(2) If a recessed area has a door, it is considered a closet, and subparagraph 1 above applies. At a minimum, the door will have unobstructed openings near the top and bottom. A fully louvered door may also be used in lieu of top and bottom openings. No other fuel burning appliances may be installed in the same closet.

n. Where dryers are located within mobile homes (See Detail No. 8), the following criteria applies:

(1) Dryers must be exhausted outside the mobile home.

(2) Metallic duct must be used.

(3) If dryer is exhausted through the floor and the area under the mobile home is enclosed, the exhaust system must extend to the outside of the enclosure.

8. Action. The guidance included in this technical letter will be used for the planning, design and construction of new and renovated facilities.

9. Implementation. This technical letter will have special application, as defined in paragraph 8c, ER 1110-345-100.

FOR THE COMMANDER:

1 Appendix  
App A - Details

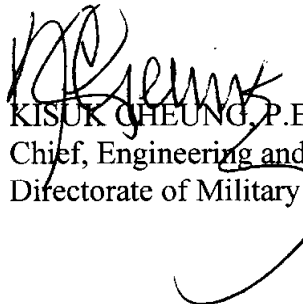
  
KISUK CHEUNG, P.E.  
Chief, Engineering and Construction Division  
Directorate of Military Programs

APPENDIX A: DETAILS

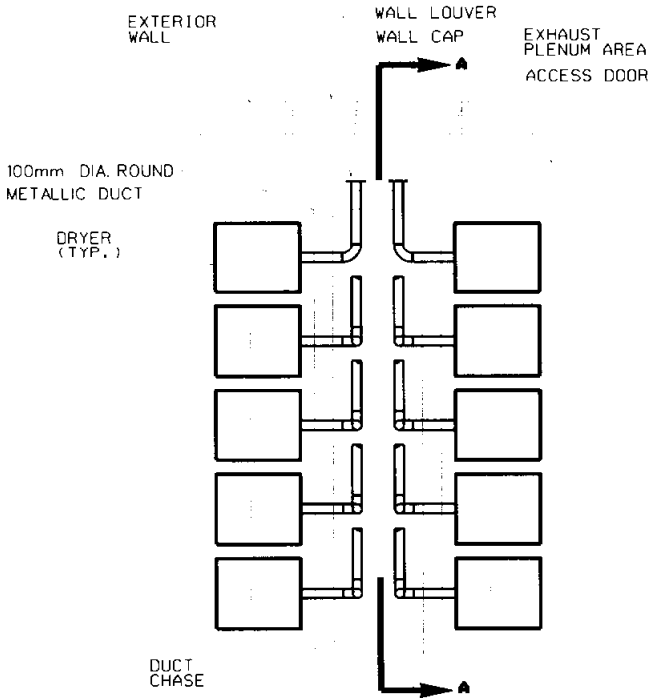

**DETAIL NO. 1: INDIVIDUAL EXHAUST VENTING TO A COYON EXHAUST PLENUM**  
NO SCALE

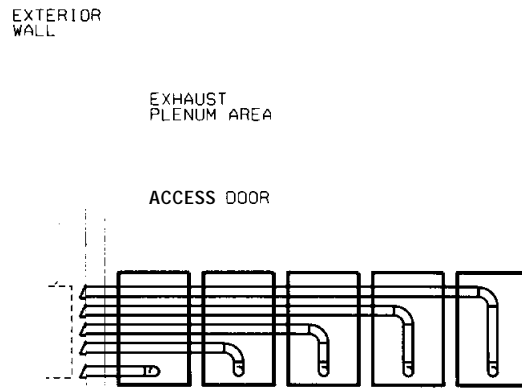

**DETAIL NO. 1: SECTION A-A**  
NO SCALE

NOTE:

DESIGNER SHALL EVALUATE PROJECT SPECIFIC PARAMETERS FOR DETERMINING MINIMUM LOUVER HEIGHT ABOVE GRADE. ISSUES SUCH AS FLOODING, SNOW BLOCKAGE, HEAT TRAP, ETC. SHALL BE EVALUATED.

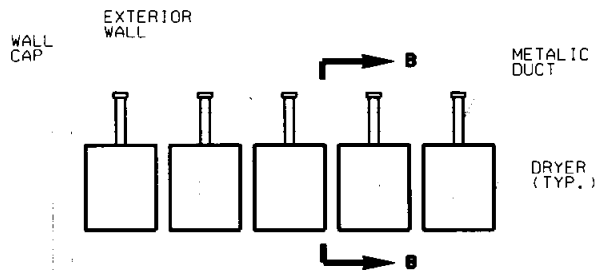

**DETAIL NO. 2: INDIVIDUAL EXHAUST VENTING TO OUTDOORS**  
NO SCALE

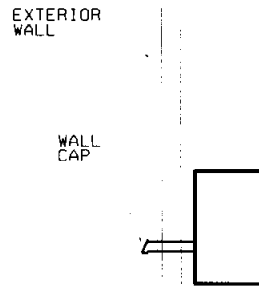

**DETAIL NO. 2: SECTION B-B**  
NO SCALE

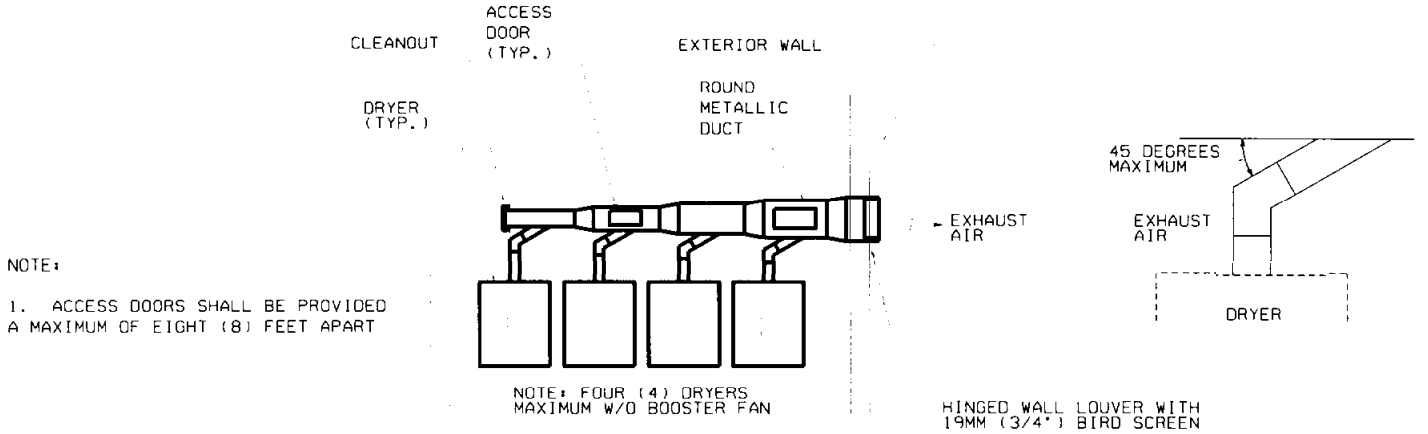

**DETAIL NO.3: MULTIPLE DRYERS  
(MANIFOLD ARRANGEMENT) W/O RACKDRAFT DAUPRR**  
NO SCALE

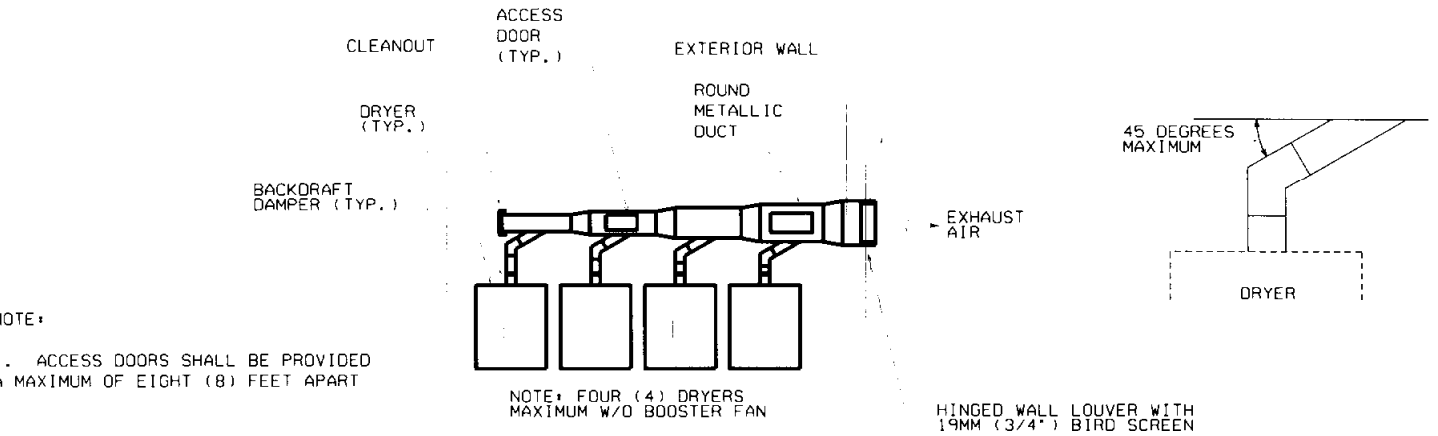

**DETAIL NO.4: MULTIPLE DRYERS  
(MANIFOLD ARRANGEMENT) W/ BACKDRAFT DAUPRR**  
NO SCALE

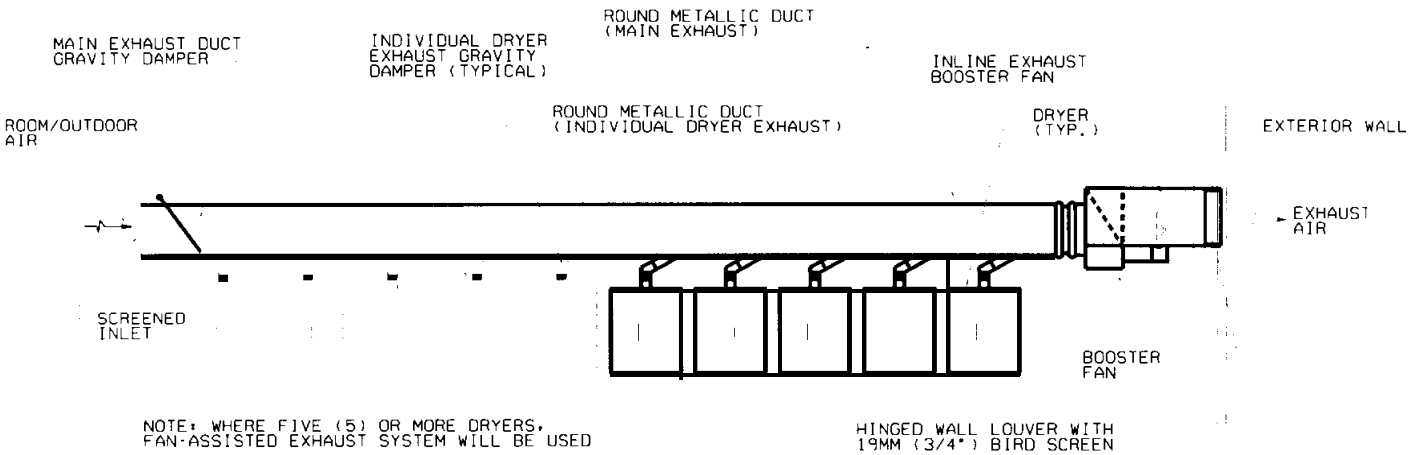

**DETAIL NO. 5: MULTIPLE DRYERS  
(MANIFOLD ARRANGEMENT) - FAN-ASSISTED**  
NO SCALE

- NOTES:
1. ACCESS DOORS SHALL BE PROVIDED A MAXIMUM OF EIGHT (8) FEET APART.
  2. DUCTS WHICH HANDLE OUTSIDE MAKE-UP AIR WILL BE INSULATED PER COLD DUCT REQUIREMENTS.



BOOSTER (EXHAUST) FAN

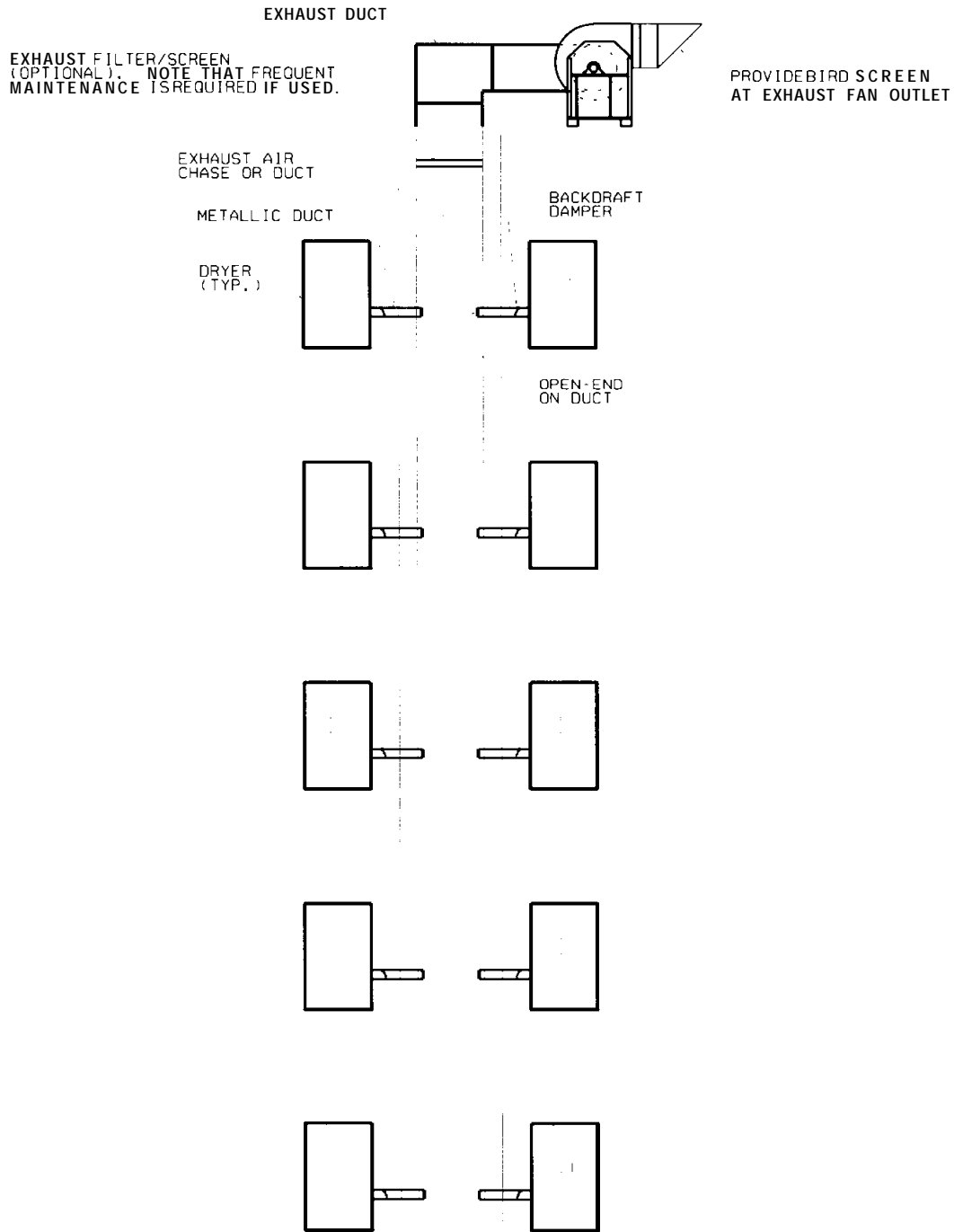

CLEANOUT PORT

BAROMETRIC DAMPER



**DETAIL NO. 6: MULTI-STORY EXHAUST VENTING (PAN-ASSISTED)**  
NO SCALE

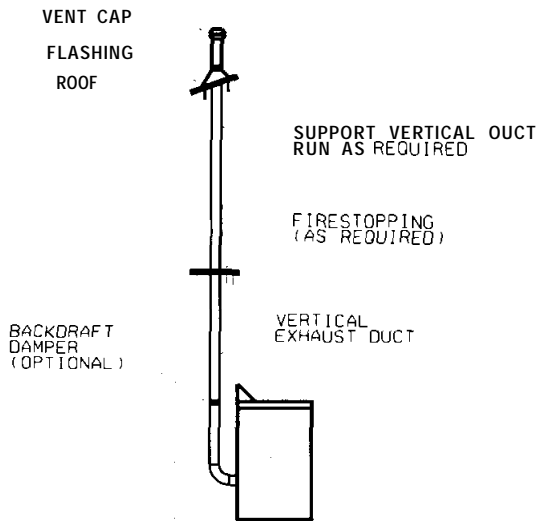

**DETAIL NO. 2 THRU-THE-ROOF EXHAUST VENTING DETAIL**  
NO SCALE

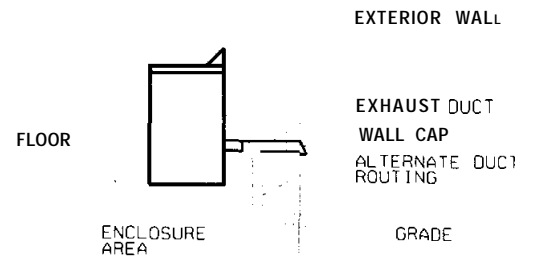

**DETAIL NO. 8: DRYER EXHAUST VENTING  
(MOBILE HOME INSTALLATION)**  
NO SCALE

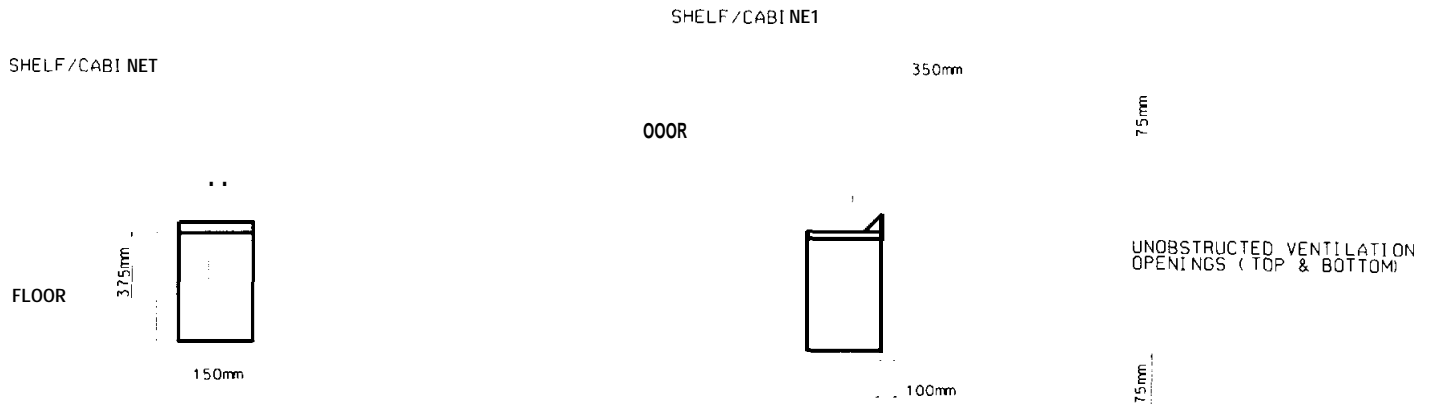

**DETAIL NO. 9: RECESSED DRYER  
INSTALLATION DETAIL**  
NO SCALE

**SIDE VIEW**  
NO SCALE

**DOOR FRONT VIEW**  
NO SCALE